

SPEA SHOWTIME PLUS

User Manual

Benutzerhandbuch

Manuel d'emploi

Manual del usuario



Part Number 1740 4020.5
Rel. 0295
Copyright by SPEA Software AG

Copyright 1995 SPEA

The information furnished in this manual is believed to be accurate and reliable. However, SPEA assumes no responsibility for its use; nor for any infringements of patents or other rights of third parties which may result from its use.

SPEA reserves the right to change the specifications of the products described in this manual in the interests of technical progress at any time without notice. No part of this document may be reproduced by any means, nor translated to any medium without prior, written consent from SPEA.

The installation program used to install the SPEA Superdisk, INSTALL, is based on the licensed software provided by Knowledge Dynamics Corp., Highway Contract 4, Box 185-H, Canyon Lake, Texas 78133-3508 (USA), 1-512-964-3994.

Knowledge Dynamics Corp. reserves all international copyright and protection rights. The INSTALL program is provided for the exclusive purpose of installing the SPEA Superdisk.

SPEA has made modifications to the software as provided by Knowledge Dynamics Corp., and thus the performance and behaviour of the INSTALL program supplied with the SPEA Superdisk may not represent that of INSTALL as supplied by Knowledge Dynamics.

SPEA is exclusively responsible for the support of the SPEA Superdisk, including the support for the installation. SPEA is responsible for the technical support.

© 1995 SPEA Software AG. All rights reserved.

Registered Trademarks

IBM PC, XT, AT and PC-DOS are registered trademarks of International Business Machines Corporation.

MS-DOS is a registered trademark of Microsoft Corporation.

AutoCAD, AutoShade and 3D Studio are registered trademarks of Autodesk Inc.

Intergraph MicroStation is a registered trademark of INTERGRAPH.

MultiSync is a registered trademark of NEC Corp.

PCI and PCI Local Bus are registered trademarks of the PCI Special Interest Group (SIG).

VESA is a registered trademark of the Video Electronics Standards Association.

Windows is a registered trademark of Microsoft Corporation.

All other names are tradenames / trademarks of their respective owners.

FCC Compliance

This board has been tested and found to comply with the limits for a Class B digital device, pursuant to Part 15 of the FCC Rules. These limits are designed to provide reasonable protection against harmful interference in residential installation. This device generates, uses and can radiate radio frequency energy and, if not installed and used in accordance with the instructions, may cause harmful interference to radio communications. However, there is no guarantee that interference will not occur in a particular installation.

Installing the Software from the SPEA Media-Gallery CD

It is possible that you have received the SPEA software on CD rather than on diskette. If this is the case, then please note that the descriptions in this manual should be changed accordingly. For example, the instructions "Put the disk 'Drivers for Windows' in drive A:" would be exchanged with the following steps: "Switch to the CD drive (e.g. D:) and enter the path of the desired driver, e.g.

D:\SPEA\INSTALL\MERCURY.P64\WIN

for the Windows driver for the V7-MERCURY P-64 board.

Other subdirectories could be 'DOS&UTIL' (for utilities and DOS tools) and 'OS2' (for OS/2 driver software).

Important Note

You must **imperatively** read the README file on your 'Utilities' disk and all the documentation supplied with your graphics board **before** installing it! If you fail to do so SPEA can not accept any responsibility for claims that may be caused as a consequence.

To see the README file, put the 'Utilities' disk in your floppy drive and type:

A:

SHOW README.ENG

Table of Contents

QUICK INSTALLATION	
WINDOWS DRIVER QUICK INSTALLATION	
GENERAL INFORMATION	
Guide to this Manual.....	
Symbols and Conventions.....	
Delivery Scope Checklist.....	
SPEA SHOWTIME PLUS Installation Disks.....	
Last-Minute Changes - README file.....	
Warranty.....	
Support.....	
Company Address.....	
PART 1 INTRODUCTION	
Features of the SPEA SHOWTIME PLUS.....	
Software for your Board.....	
PART 2 HARDWARE INSTALLATION	
Graphics Card Installation.....	
Requirements and Considerations.....	
Monitor Compatibility.....	
Typical System Configuration.....	
Preparing your Computer.....	
CGA or Monochrome board installed before?.....	
Installing the SPEA Card.....	
Connecting External Equipment.....	
Installation of the SPEA SHOWTIME PLUS with a sound card (V7-media fx).....	
Installation of the SPEA SHOWTIME PLUS without a sound card.....	
Additional Installation Instructions.....	
After Installing the SPEA Board.....	
Tips and Tricks for installing the SPEA SHOWTIME PLUS.....	
PART 3 SOFTWARE INSTALLATION AND CONFIGURATION	
Windows 3.1x.....	
V7SETUP.....	
SPEA WinTools.....	
SPEAenergy (DPMS).....	
MediaStation.....	
Using the MediaStation Remote Control.....	
MPEG / AVI / VideoCD Playback.....	
Video In Capture (AVI).....	
Single Frame Capture (all formats).....	
OS/2.....	
WIN-OS/2 Full Screen Refresh rates.....	
AutoCAD, AutoShade, 3DStudio.....	
MicroStation.....	
Windows NT.....	
APPENDIX A UTILITIES	
STMODE - Setting the Monitor frequency.....	
STTEST - Hardware Test.....	
APPENDIX B TECHNICAL DETAILS	
Technical Data.....	
Memory Addresses of the SPEA SHOWTIME PLUS.....	
Video Modes.....	
The Connections of the SPEA SHOWTIME PLUS.....	
VGA Video Output Connector.....	

Pinout of the SPEA Movie Bus.....

APPENDIX C TROUBLESHOOTING.....

General Considerations.....

 Systems with motherboard VGA controllers.....

 Hardware settings.....

Configuration Problems with PCI Motherboards.....

Frequently Asked Questions.....

 General problems.....

 Problems with Windows.....

 Problems with MediaStation or Media Player.....

 Problems with VideoCDs.....

 Problems with CD ROM Drives.....

APPENDIX D GLOSSARY.....

INDEX..... 37

Quick Installation

This Quick installation is for **experienced users only!** Other readers should take the time to read the manual.

1. Make a backup copy of the disks supplied with the board.
2. Check that your monitor and system configuration support the SPEA graphics card (e.g. correct bus type and version).
3. Disconnect your computer from the mains power and peripheral equipment.
4. If your system main board incorporates a video adapter deactivate it or deinstall other VGA board - if present.
5. Install your SPEA graphics board in a free extension slot.
6. Reassemble your PC, connect peripheral equipment and reconnect the power cable.
7. Reconnect any peripheral equipment (e.g. loud speakers).
8. Switch on your monitor first, then the computer.
9. At the DOS prompt insert the SPEA disk 'Utilities' and start the software installation with:

```
A:  
INSTALL
```

Windows Driver Quick Installation

1. Windows must already be configured for standard VGA (640 x 480) before the SPEA Windows driver can be installed.
2. Start Windows.
3. Put the SPEA 'Drivers for Windows' disk in your drive.
4. Start the Program Manager. Select the options 'File', 'Run' and then select A:\V7SETUP.EXE.
5. Select a language in the SPEA dialogue box which appears.
6. Select a screen video mode.
7. For future sessions: video modes can be set and changed using the V7SETUP dialogue box (SPEA Program Group).

Problems?

In the unlikely event of problems ...

1. Check the README file in your C:\SPEA\SHOWTIME directory
2. Read *Appendix C: Troubleshooting*.
3. If you have installation and application problems with your SPEA graphics board you can obtain technical support via the SPEA Support Mailbox
4. Take note of your warranty - see *section Introduction*
5. Contact the SPEA ExpertLine (see extra pamphlet)

Your board is a complex electronic device and can only be repaired by authorized technical personnel with the required equipment. Do **not** attempt to change or repair any parts of this product. Doing so will render your warranty invalid.

General Information

Guide to this Manual

This manual is divided into five parts:

Part 1	Introduction
Part 2	Tells you how to physically install the graphics board.
Part 3	Provides information for installing the application drivers included on the SPEA Superdisk.
Appendices	Contain other information that you should review.
Index	To enable you to find subjects in this manual quickly.

Symbols and Conventions

The following symbols and syntax conventions are used in this manual:

Warning!

This section contains a warning or important information.

Note: This section contains useful hints. **DOS commands** are written in capital letters, example:

```
A:  
INSTALL
```

If not defined in another way, all DOS commands must be confirmed with the ENTER or RETURN key.

Example: Examples are indicated by this format.

Screen messages are shown in *Courier*. References to **other parts of the manual** are shown in *italic*.

Directory names mentioned in this manual are exemplary and written in capital letters. The SPEA V7 Superdisk is delivered on 3,5" format. Therefore, the documentation refers to disk drive A:. Please enter B:, if your 3,5" disk drive is addressed with B:.

Delivery Scope Checklist

Your SPEA package should contain the following items:

- 1 SPEA SHOWTIME PLUS
- the following 3.5" disks:
 - 1x 'Basic Installation'
 - 3x 'Drivers for Windows'
 - 1x 'Drivers for OS/2'
- SPEA ExpertLine Info sheet
- this manual

SPEA SHOWTIME PLUS Installation Disks

The SPEA software is supplied on high density (1.4 MB) 3,5" floppy disks. The current utility software and various drivers are available around the clock and can be downloaded from the SPEA Bulletin Board (Mailbox).

Last-Minute Changes - README file

Our software is constantly being improved and updated. The latest information is contained in a file README.

The README file appears on the screen automatically at the end of the software installation. You can also read this file at any time from your hard disk (after the installation) with the command:

```
SHOW README  
or from your diskette with:  
A:  
SHOW README.ENG
```

Warranty

You have a 3 year warranty for your SPEA graphics card. To ensure your warranty, it is necessary that you keep the invoice of the graphics card. If your graphics card is damaged, contact your local retailer first. Your board is a complex electronic device and can only be repaired by authorized technical personnel with the required equipment. Do **not** attempt to change or repair any parts of this product. Doing so will render your warranty invalid.

Support

The following support services are offered by SPEA Software AG:

- technical support (telephone, SPEA ExpertLine)
- Online information and software updates per modem (SPEA Mailbox)
- software updates on disk via the SPEA UpdateService

Further information concerning these support services can be found in the 'SPEA ExpertLine' pamphlet (colored info sheet) enclosed with your board.

Company Address

SPEA Software AG
Moostr. 18B
D-82319 Starnberg

Tel: +49 81 51 26 60
Fax: +49 81 51 21 258

Part 1

Introduction

Your SPEA board is a high-resolution, VGA compatible **graphics accelerator** specially designed to speed up applications running in graphics-intensive environments such as Windows and OS/2. At the same time, it is a versatile, all round **multimedia board** offering advanced features (such as MPEG playback) as described in the following section.

Features of the SPEA SHOWTIME PLUS

- advanced Tseng W32P graphics processor for VESA Local Bus and PCI 2.0 bus systems
- board incorporates a 135 Mhz RAMDAC for high performance graphics output
- standard of 2 MB DRAM onboard
- TrueColor (16.7 million simultaneous colors displayed) for resolutions up to 800 x 600
- maximum (non-interlaced) display resolution of 1280 x 1024 (256 colors)
- refresh rates up to 90 Hz at 800 x 600 give absolutely flicker free performance
- chip-integrated drawing functions to optimize graphics oriented applications
- power management (DPMS) software included to use the VESA specified modes to reduce power consumption
- enhanced driver software for most major applications
- **MPEG:**
hardware supported MPEG video and audio realtime playback (MPEG 1 standard files), scaleable from 16 x 16 to 720 x 576 in a window or full screen. Frame rate 30 fps (NTSC) or 25 fps (PAL).
- high quality VideoCD movie playback support
- **Audio support:**
16 bit stereo, 44.1 kHz (CD quality)
MPEG audio layer I and II
line level to 3.5 mm mini jack for connection to active loudspeakers or a sound board

- **Live Video input: (e.g. from tuner board VCR or camcorder in PAL, NTSC or SECAM format)**
 - Y/C composite video input
 - S-VHS video input
 - scaling and rates as with MPEG
 - still video and live video capturing

Check the glossary in this manual for a brief description of the abbreviations used here (e.g. MPEG).

Power Management:

The utility SPEAenergy enables you to set the VESA specified DPMS modes to reduce the power consumption of your system.

Software for your Board

Various software drivers for standard applications as well as useful utilities are supplied with your board. Additional software (drivers for specific applications) are also available, but not a part of the standard delivery scope.

Standard Software Delivery

- Menu driven installation program to easily install the software
- SPEA MediaStation (SPEA's video control software under Windows)
- MCI Windows drivers for MPEG Audio and Video
- Software drivers for Windows, OS/2 and Video for Windows
- Basic software and Utilities for the configuration

Optional Software

This software will be available free of charge via SPEA's Mailbox (and partially via CompuServe)

- Drivers for MicroStation, AutoCAD, 3D-Studio, AutoShade and Windows NT

Part 2

Hardware Installation

Graphics Card Installation

quency 50 kHz; max. vertical frequency (refresh rate) 90 Hz.

Requirements and Considerations

1. IBM compatible computer (80386/486/586) with PCI or VESA local bus system.
2. One free PCI or VL Bus system expansion slot
3. MS-DOS operating system, version 5.0 or later
4. at least 4 MB RAM
5. Screwdriver

Warning!

Prevent damage by static electricity. Static electricity can cause severe damage to microcircuits, but here are some easy ways to see that it doesn't happen.

1. Hold the SPEA card on its **edges only**. Don't touch edge connectors or exposed circuitry.
2. Leave the SPEA card in the anti-static protective bag until ready to install it in your computer.
3. If possible, ground your body when handling the SPEA card. The metal power supply housing is generally considered the best place to ground yourself.
4. Do not place the SPEA card on a metal surface.
5. Make the least possible movement to avoid building up static electricity from your clothing, carpets and furniture.

Monitor Compatibility

The boards of the SPEA series offer high performance in resolutions, refresh rates and colors. Especially the ergonomic SPEA refresh rates up to 90 Hz give absolutely flicker free performance. The SPEA boards are optimally configured to be combined with the SPEA MultiSync monitors.

Of course SPEA boards can also be connected to other VGA or high resolution MultiSync monitors. Please be aware of the fact, that you can only get use of the full power of the graphics board if the horizontal (kHz) and vertical (Hz) refresh rates of your monitor are as high as required by the graphics board.

Example: The technical specifications of a multisync monitor could be as follows: max. resolution 1280 x 1024; max. horizontal fre-

If you wish to use one of the video modes listed in the file BIOS.TXT included with this product, then all three of the above mentioned parameters may not exceed the specifications of this monitor.

In our example, the mode 1024 x 768 with a horizontal frequency of 48.5 kHz and a refresh rate of 60 Hz may be selected, whereas the next higher refresh rate of 70 Hz (at the same resolution) is not possible, as the required horizontal frequency is 56.5 kHz in this case, which exceeds the specifications of the monitor.

Warning!

If you permanently activate your monitor with frequencies that are too high you may damage the monitor. Therefore before you start to change the refresh rate with programs described in section 3 (e.g. V7SETUP), have a look in your monitor manual about its technical data (horizontal and vertical refresh rate, possible resolutions).

Typical System Configuration

A typical configuration environment your board is described as follows:

- Colani Tower 486DX-40, VL bus, 40 MHz, 4 MB or Colani Tower 486DX2-66, PCI bus, 66 MHz, 8 MB
- SPEA 2185 MS Monitor
- Double speed CD ROM drive

Note:

Further information concerning CD ROM drives that have been tested can be found in the README file on the Basic Installation disk (use the command A:\SHOW README.ENG).

Preparing your Computer

Please note, that the applications you want to install SPEA drivers for have to be already completely installed (for Standard VGA (640 x 480, 16 colors) on your system prior to using the SPEA software. It is a good idea to do this before removing an existing graphics adapter as not every application permits the configuration of the video mode used from the DOS plane.

PCI cards

It is very important to have the correct configuration for the PCI expansion slot to be used for the SPEA SHOWTIME PLUS. The hardware settings are made using the system BIOS setup. We cannot provide detailed instructions as system BIOS setup programs vary considerably from one BIOS type to another.

Warning!

Make a note of the system BIOS setting BEFORE making changes. Inappropriate changes made to the system BIOS setup can cause major hardware conflicts with various parts of the computer.

You should note the following when installing the SPEA SHOWTIME PLUS in your computer:

- You must install the SPEA SHOWTIME PLUS in the PCI Master Slot.
- The slot interrupt INT-A must be assigned to one of the available system interrupts (for example: IRQ 10)
- Check in the motherboard manual if a jumper needs to be set. Jumpers are sometimes used to assign INT-A to the PCI slot being used by the SPEA SHOWTIME PLUS.

Some recent motherboard designs have a Plug & Play system BIOS. If you have such a PCI system, the BIOS will do the interrupt configuration automatically.

If you still have problems with your PCI configuration you'll find additional information in *Appendix C 'Troubleshooting'* in this manual.

VL cards

There are no special hardware settings to be made before installing the SPEA SHOWTIME PLUS into a VL slot. During the software installation (which will be described in chapter 3 in this manual), you will be asked to select an IRQ for the SPEA SHOWTIME PLUS. We suggest you use IRQ 10 -if available.

CGA or Monochrome board installed before?

If a CGA or was previously installed, it is necessary to change the PC's hardware configuration. This is sometimes done by changing a jumper on the motherboard after removing the old board (check your motherboard or PC manual) although it more common to change your PC's BIOS SETUP.

Exception:

If you have a system with a EGA/VGA display adapter built onto the motherboard. In this case, the on-board EGA/VGA display adapter **must** be disabled before installing the SPEA card.

Please check your PC manual to find the location of the corresponding switch.

Warning!

Simultaneously using two active VGA/EGA units in one PC will inevitably lead to system failure!

If your system doesn't have to be re-jumpered for a VGA board then first proceed with the following installation steps and then run your BIOS SETUP program and select 'VGA' (else 'IBM VGA') as your graphics board type. Check your PC manual for information on its BIOS SETUP.

1. Switch off your computer and all external options (printer, display, and others) and unplug all power cords from the electrical source.
2. Remove the cover mounting screws and save them for later.
3. Remove the cover of the computer.

Installing the SPEA Card

The SPEA card is installed in an expansion slot corresponding to the bus type (VL local bus or PCI bus).

1. Select a free expansion slot and remove its metal slot cover. Save the screw to secure the graphics card later.
2. Hold the card by the edges and press it firmly into the expansion slot.

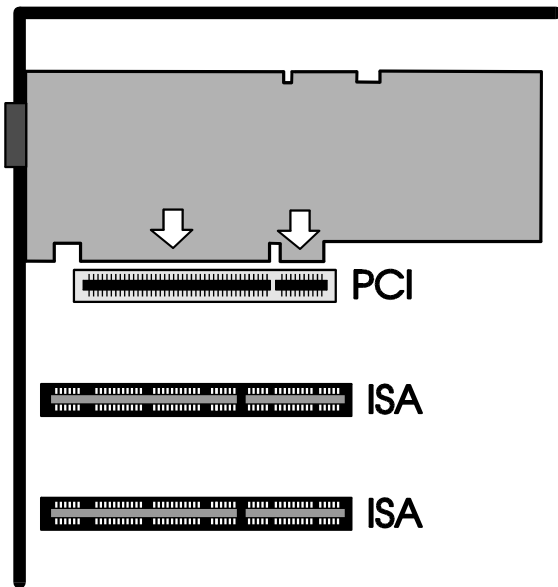

3. Align the slot in the mounting bracket of the SPEA card with the screw hole in the rear panel of the computer case. Use the screw you removed from the expansion slot cover or the previously installed video adapter to secure the SPEA card in place.
4. Secure ribbon cables and gently push them down and out of the way before you replace the system cover.
5. Fix and secure the system cover on the PC again.
6. Reconnect any peripheral equipment cables you may have disconnected.
7. Securely attach your monitor cable to the 15-pin video connector. Connect the other end of the cable with your monitor as described in the monitor manual.
8. If you intend to use active loudspeakers, a sound board or a video in source (e.g. camcorder, TV tuner board or Video recorder) then refer to the next section for details on making the right connections.

Installing the Card in a PCI Local Bus Slot

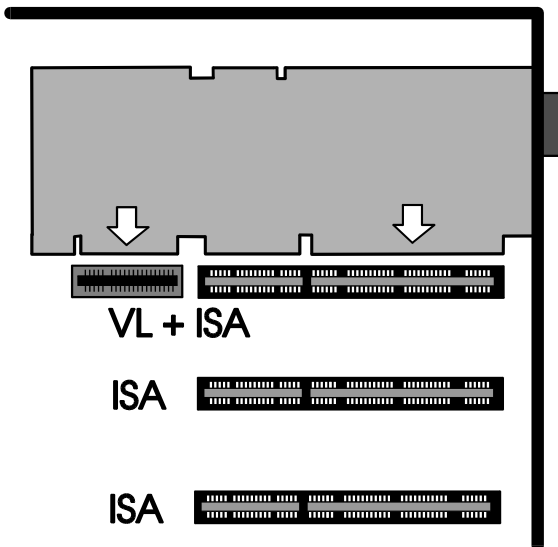

Installing the Card in a VESA Local Bus Slot

Warning!

The following step is very important in order to ground your SPEA card properly.

Connecting External Equipment

The connectors on the board are standardized, with the exception of the SPEA Movie Bus (see Appendix B, Technical Details). For this reason, you only need to take note of a few points when making connections to external equipment.

Warning!

Be sure to connect any peripheral devices to the computer and switch them on before switching on your computer. This avoids a damaging power surge, and the possibility of electrical discharge damage when live connections meet.

- Audio Out
This is a 'line out' output, i.e. low level voltage. This means that you can either connect this output to **active loudspeakers** (ones with a built-in amplifier, recognizable by the volume control on the loudspeakers themselves) **or your Hi-Fi system** (the output signal is too weak for normal loudspeakers) or to a **sound board**, such as SPEA's V7-media fx. This output provides a stereo signal (3.5mm stereo jackplug connection), however a mono jackplug can also be used without danger of short-circuiting the SPEA SHOWTIME PLUS.
- Composite Video In
This can be connected to a VCR (video recorder), TV tuner board or camcorder output socket. **Note that the antenna signal from the wall socket is not suitable!**
- SVHS Video In
The same applies as for the Composite Video In socket. The difference is that the quality of an SVHS signal is better due to separate signal lines. Use this input if your video signal source has an SVHS output.
- SPEA Movie Bus
This connector is intended for use with future SPEA products, such as MJPEG boards. The necessary cables will be available with the future products.

Installation of the SPEA SHOWTIME PLUS with a sound card (V7-media fx)

There are a number of ways to connect the SPEA SHOWTIME PLUS and peripheral devices. The following schematic diagram shows a typical arrangement, enabling you to use all the features of the SPEA SHOWTIME PLUS.

Connecting your SPEA SHOWTIME PLUS and peripheral devices as shown in the following diagram will give you a complete multimedia system, with which you can play VideoCDs, video tapes and stereo music in Windows.

SPEA's soundcard V7-media fx is an ideal partner for the SPEA SHOWTIME PLUS. It provides high quality audio output and has three CD-ROM interfaces built-in, saving you a valuable expansion slot.

If you are not using a V7-media fx card, you will still be able to make similar connections to your sound card.

Note:

VHS video tapes can be played on most S-VHS video recorders (in VHS mode), but video tapes with S-VHS recordings cannot be played on a VHS video recorder.

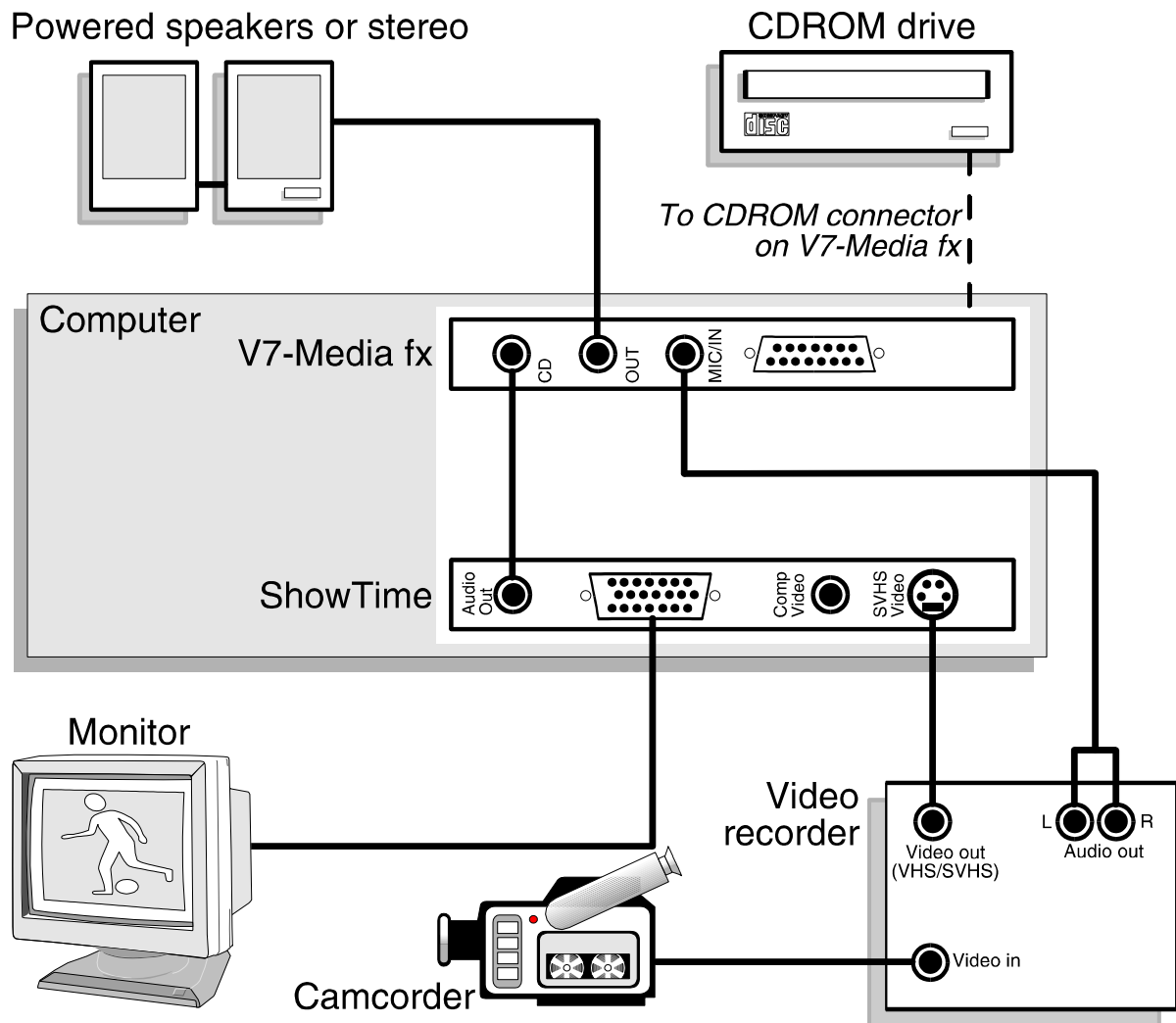

Installation of the SPEA SHOWTIME PLUS without a sound card

With this configuration you can play VideoCDs with sound processed directly by the SPEA SHOWTIME PLUS.

Warning!

The SPEA SHOWTIME PLUS is designed to provide audio sound only for MPEG playback. All other sound output requires a separate sound card. This is because MPEG uses digital sound and VHS recordings use analogue sound. Analogue sound is normally processed on a sound card as WAV information.

Powered speakers or stereo

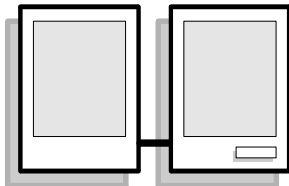

CDROM drive

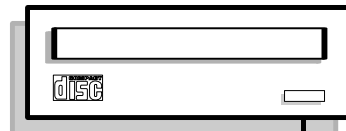

To CDROM
controller card

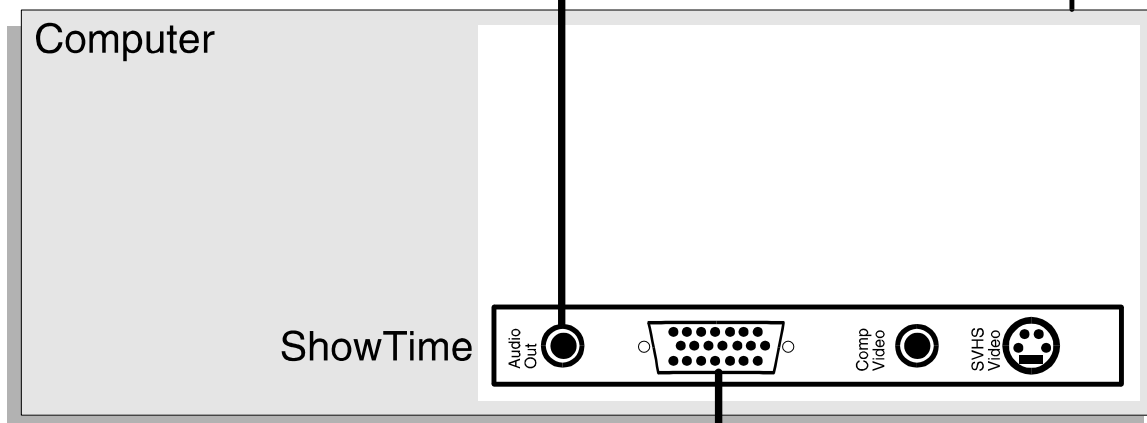

Monitor

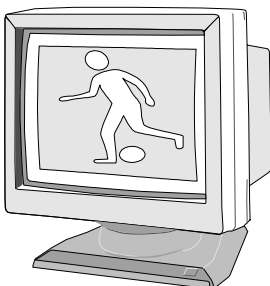

Additional Installation Instructions

Monitor

Please switch on your monitor **before** you switch on your computer. Doing it the other way around could damage your monitor.

Note that your monitor is running in standard modes and that higher refresh rates etc. are not available at this stage of the installation! It is necessary to run the programs STMODE.EXE (for DOS applications) and V7SETUP.EXE (for Windows) in order to optimize the board's output signals for use with specific monitors. These programs are described further on in this manual.

Hardware Compatibility: the VL/PCI Bus and the Graphics Board

The functionality of a graphics system depends mainly on two components: the graphics board and the mainboard.

If either the design of the VL bus or the PCI mainboard is not compliant with the approved VESA or PCI specifications you may experience problems with the graphics board.

SPEA has successfully tested the SPEA VL bus graphics boards in VL bus mainboard with a clock rate of 40 MHz and PCI bus mainboards with a clock rate of 66 Mhz.

After Installing the SPEA Board

If you have correctly installed the SPEA board, the DOS prompt will appear on your monitor when the boot procedure is finished.

If your system does NOT boot it should, check again to see that the installation instructions were properly followed, or refer to *Appendix C (Troubleshooting)*.

Important!

Before installing the supplied software, make a backup of the SPEA installation disks. Use the backup copy for your installation and store the originals in a safe place.

Tips and Tricks for installing the SPEA SHOWTIME PLUS

Keep it simple to begin with

Although it may be tempting when installing the SPEA SHOWTIME PLUS, to connect your video recorder, stereo, CD-ROM and Camcorder, it is wise not to try to do everything at once. Make sure your CD-ROM drive and sound card (if fitted) are working properly beforehand.

Make the connections properly

If just one of the cables is not connected correctly, the flow of data from input to output will be broken and one or more part of your multimedia system will not work properly. As many of the standard cables are very similar, it is possible to make a mistake.

Initialise the SPEA SHOWTIME PLUS and V7-media fx before use

In your AUTOEXEC.BAT file, be sure to include the following lines (normally these lines are automatically added by the software installation program):

```
CALL C:\SPEA\SHOWTIME\SOUND  
(initialises the SPEA SHOWTIME PLUS)  
CALL C:\SPEA\GDC\SSINIT GM  
(initialises the V7-media fx (if installed)).
```

Part 3

Software Installation and Configuration

Please note, that the applications you want to install SPEA drivers for have to be already completely installed (for Standard VGA (640 x 480, 16 colors) on your system prior to using the SPEA software. It is a good idea to do this before removing an existing graphics adapter as not every application permits the configuration of the video mode used from the DOS plane.

Note:

Our software is constantly being improved and updated. This means that it may not have been possible to document the most current changes in this manual. The latest information is contained in a file named README.

Please check the exact directory names and paths of your applications, as you will be asked for these during the software installation of the SPEA drivers.

1. Insert the SPEA SHOWTIME PLUS installation disk 'Basic Installation' in drive A:
2. Start the installation with the following call:
A:
INSTALL
3. Select a language for the installation procedure.
4. Follow the instructions on the screen. Via various utilities all the necessary settings will be made.

Note:

In case you have problems configuring your PCI board you can find additional information in *Appendix C: Troubleshooting*. During the installation the environment variable GDC which will be necessary from now on, will be set. Therefore a batchfile (SETGDC) will be created and an entry in the AUTOEXEC.BAT file will be set.

Warning!

Most applications require you to reconfigure them to use your SPEA graphics board. Please refer to the sections of the relevant software application to complete your installation correctly.

Before you start to configure the software applications, you may wish to change the monitor settings, resolutions or number of colors used. This is handled by the program STMODE.EXE for DOS applications and V7SETUP.EXE (within Windows) for Windows applications.

Windows 3.1x

Requirements:

- The SPEA SHOWTIME PLUS must be installed in your system before you can install the SPEA driver.
- Windows must be installed and configured for standard VGA.
- If you are using a separate sound card, ensure that it is installed and working correctly in Windows.
- The environment variable GDC must be set.

1. Start Windows and insert the ShowTime Plus disk 'MCI Windows Drivers for MPEG' in drive A:.
2. In the Program Manager select 'File' 'Run' and in the appearing dialogue box enter A:\V7SETUP.EXE.
3. Select a language in the corresponding dialogue box and then follow the instructions on the screen.

Note:

It is possible that not all the installation disks will be required by the installation program.

During the installation the program group 'SPEA' with various icons is created.

4. At the end of the installation Windows will be restarted with a resolution of 640 x 480, Hicolor and with 60 Hz.
5. Via the V7SETUP you can now optimally modify your screen display.

V7SETUP

What is V7SETUP?

SPEA V7SETUP is a program with various options to set the monitor used, resolution, colors, refresh rates etc. for **Windows applications** (the monitor settings used for DOS applications are made using the program STMODE - see Index).

How is SPEA V7SETUP used?

Double click on the SPEA icon, the menu then will appear.

Configure your system paying attention to the abilities of your monitor.

Note that if you activate the option 'enable 8 bit Hardware support', all 256 color modes will be automatically deactivated as you cannot playback MPEG and AVI files with them.

Warning

You can damage your monitor if you select a refresh rate that is too high for it! Read your monitor manual refresh rate information. Changes made via SPEA V7SETUP are only activated after Windows has been restarted. The test button is only active for the current color depth. If you change the settings it will be deactivated. Restart Windows with the new settings and call SPEA V7SETUP again, the button will be active again.

SPEA WinTools

SPEA offers its customers various tools which can be used to simplify or enhance the use of Windows.

SPEAenergy (DPMS)

What is SPEAenergy?

SPEAenergy is a power management utility (DPMS) for Windows.

DPMS is a specification set by VESA which defines modes for reducing the power consumption of monitors and video devices. You can use SPEAenergy to reduce power consumption by defining timeout values, e.g. for the deactivation of certain circuit elements which reduce the power consumption level in stages (e.g. from 120 W to 100 W to 30 W to 5W)

Warning!

You must have a monitor that supports DPMS. Via a dialog box you can activate 4 different DPMS modes.

The 4 DPMS modes are: ON, STAND-BY, SUSPEND and OFF.

How can you install SPEAenergy?

Put the disk with the SPEAenergy software in drive A:. Start Windows.

In the Program Manager select 'File' 'Run'. Set the path to drive B: and select the file SPENERGY .EXE. Confirm your selection with OK.

The SPEAenergy icon will be placed in the SPEA program group.

How can you work with SPEAenergy?

Start SPEAenergy by double clicking on the SPEAenergy icon. A self-explanatory dialog box appears for defining your settings. If you need help, consult the online help integrated in this program.

If you want to finish SPEAenergy you have to close the SPEAenergy icon that is residently placed at the bottom of your monitor display.

MediaStation

MediaStation is SPEA's easy-to-use control software to playback MPEG 1 (*.MPG), *.VPG, *.AVI and VideoCD *.DAT files under Windows.

The TV's remote control can be used to select and playback files or films (e.g. VideoCDs), program and save film sequences, modify the volume, colours and display size.

When you click on the MediaStation icon in the SPEA program group, the remote control appears on the screen. Click on the power button on the top left side of the remote control to switch on the TV window on the screen. The functions on the remote control correspond to the ones of a real TV's remote control.

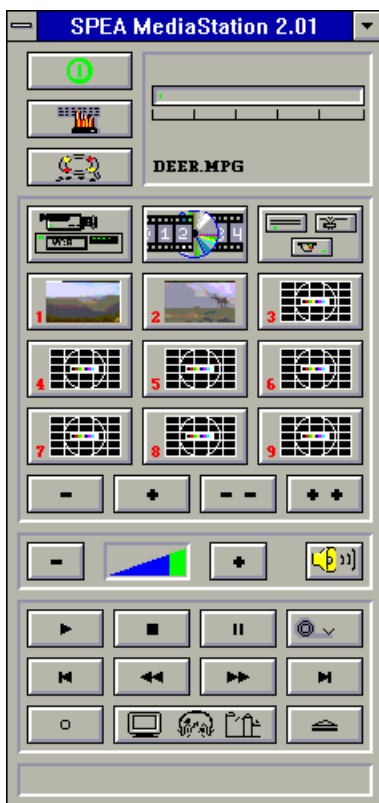

Via MediaStation's online help you can obtain additional information about all the buttons and dialogue boxes of MediaStation. Just click on the 'lifebelt' on the remote control. If you have problems playing back files please refer to the Troubleshooting section at the end of this manual.

Important Notes:

1. Only use VideoCDs labelled with 'VideoCD', other CDs will probably not be readable.
2. Handle Video Cds with great care. Due to the nature of the data they contain, they are much more sensitive to surface damage than ordinary music CDs.
3. Standard MPEG 1 and AVI files can be played back with MediaStation, however, check your README file for information on the current support status!
4. You **must** be using either a HighColor (65.536 colors) or TrueColor (16.7 million colors) mode to playback MPEG and AVI files. To make sure this is the case, click on the V7SETUP icon in the SPEA group and select an according mode.

We've kept the following descriptions very brief as we intend to integrate multimedia features as they come onto the market. Check your README file and the MediaStation online help for the latest information on file playback and recording.

Using the MediaStation Remote Control

Note that the function of a button on the control is displayed in the lower bar of the control when the cursor is positioned over it. If you're unsure about the exact function consult the online help.

Playback Speed & Volume

The playback volume is primarily controlled by the Media Player program (MPLAYER.EXE) supplied with Windows.



If you turn the volume off here, then the remote control volume will have no effect! If you are using a sound board which has a separate volume control, make sure that this is not muted or turned down! If it is, the MediaStation will not playback with sound. To change the Media Player settings it is necessary to close the MediaStation remote control first!

The speed of film files is fixed and can only be reduced to step mode (the snail button on the control). Changes to the Windows Media Player have no effect.

MPEG / AVI / VideoCD Playback

1. Open the MediaStation remote control
2. Click the right mouse button over a channel on the remote control. The file selection box appears:

You can drag & drop a file from the file selection box to a channel of the remote control using the left mouse button!



3. Select a channel number, then drive, directory and file type before picking a file
4. Click on the 'Thumbs-up' (OK) button. The selected file is transferred to the selected remote control channel (e.g. 1)
5. Click on the respective channel button on the remote control to open the TV and prepare the film
6. Click on the Play button of the remote control

Tips:

To shortcut the playback procedure, doubleclick on the file in the selection box. It is then played back *without* being saved to the selected remote control channel. The file is only transferred to a channel when you confirm with the OK button.

To see a preview of the film, pick a file with a single click of the right mouse button. A miniature film preview is then loaded which can be played back with the play button under the image.

Video In Capture (AVI)

1. Open the MediaStation remote control
2. Click the Video In button and then the Advanced Configuration button of the remote control (see online help) and select the type of input signal (PAL etc.) before making the changes you require for the capture file (length, size, frame rate etc. in the same dialogue box)

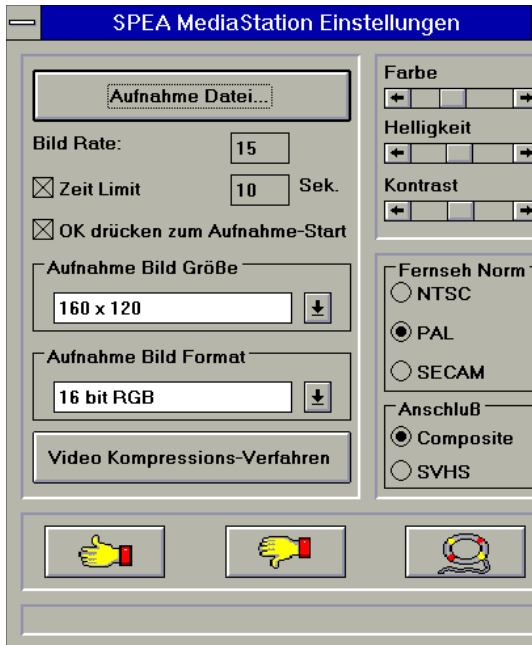

3. Click on the option 'Capture file' and enter a path and file name.
4. Make sure the option 'Hit OK to capture' is marked and the time limit set to 10 seconds. Click on OK.
5. Start your Video In source (e.g. camcorder or VCR)
6. Just before the first frame of the recording sequence click on the red record button of the MediaStation (a dialogue box with OK appears)
7. Hit the Enter key to start the recording into an AVI file when you reach the first recording image. The default AVI file is CAPTURE.AVI, located in your SHOWTIME directory.

Worth knowing ...

- A recording for about 10 seconds needs about 4 MB space on your hard disk.
- Recordings into a RAMDRIVE are smoother than those made directly onto a hard disk. They do not playback faster but jump less than hard disk recordings.
- The best AVI playback results are achieved with the 160 x 120 resolution

Single Frame Capture (all formats)

It is possible to capture a single frame of an AVI, MPEG or other playable file in two ways:

With SPEA's MediaStation

Requirement: Video In is active on the TV window.

1. Click on the Pause button when the frame you want to capture appears on the TV. With the << and >> buttons you can exactly select the desired frame.
2. As soon as you the frame is shown click on the Record button.

Note:

Instead of clicking onto the Pause button and then on the Record button you can also click with the right mouse button ONTO the active TV, the result is the same.

The following dialogue box appears where you can define the snapshots. More information you'll find in the online help of the dialogue box.

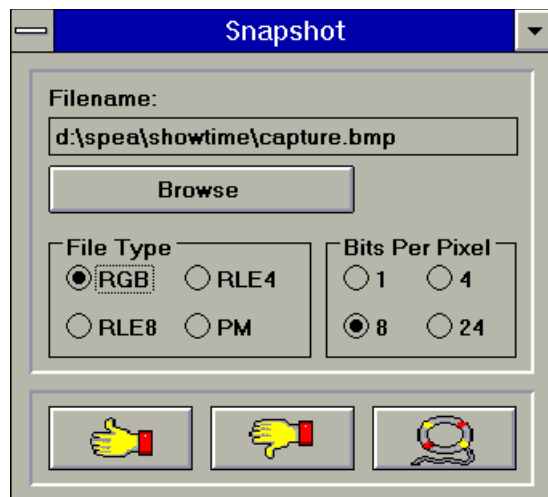

3. As soon as you click on the OK button a snapshot will be saved as BMP file.

You can edit this Bitmap file in programs like e.g. Paintbrush.

With a Windows Hotkey function

1. Start the playback of the file you want to capture a frame of
2. Pause or stop the playback when you reach the frame you need
3. Click on the MediaStation TV window frame
4. Hit the combination ALT + Print

The window is then captured into the Windows Clipboard. Using Paintbrush (for example) you can then edit the picture and if necessary

remove the border of the captured image that looks like a TV frame.

OS/2

Note:

The supplied OS/2 display drivers support the graphic functions of the SPEA SHOWTIME PLUS under OS/2 WPS and WIN-OS/2, but do not support the hardware accelerated video functions.

1. Start the OS/2 System.
2. Open the Command Prompts folder.
3. Open either an OS/2 Window or OS/2 Full screen.
4. Insert the SHOWTIME driver installation disk for OS/2 in drive A:.
5. Enter the following commands:
INSTALL A: C:

where A: is the drive with the installation disk and C: is the drive with OS/2.
6. From the 'Display Driver Install' window, select 'Primary Display' and then 'OK'.
7. From the 'Primary Display Adapter Type' window select 'Tseng Laboratories ET4000/W32/W32i/W32p' and then 'OK'.
8. From the 'Monitor Configuration/Selection Utility' window select 'Install using display adapter utility program' and then 'OK'.
9. From the 'Monitor configuration/Selection Utility location' window enter

\\SETMODE.EXE

and then click on 'OK'.
10. SETMODE will prompt you to set refresh rates for 640 x 480 resolution, then for 800 x 600 and finally for 1024 x 768. Currently available choices are shown in parentheses. The refresh rates selected will apply to OS/2 Desktop and Seamless windows.
11. From the 'Select Display Resolution' window select the desired resolution and then 'OK'.
12. From the 'Source Directory' window select 'Install'.
13. When the drivers are completely installed, you will be prompted to shut down and

restart the system for changes to take effect.

14. Now select 'OK'.

15. Remove the diskette from drive A:, then shut down the system and restart it.

You may also reference installation instructions in the OS/2 Version 2.1 Installation guide.

WIN-OS/2 Full Screen Refresh rates

To set a refresh rate of 72 Hz for 640 x 480, 800 x 600 and 70 Hz for 1024 x 768 for Win-OS/2 full screen do the following:

1. Copy VMODE.COM from the W32/W32i/W32p driver disk to your utilities directory.
2. Add the following commands to the AUTOEXEC.BAT file:

```
C:\UTIL\VMODE 72 Hz  
C:\UTIL\VMODE 48K  
C:\UTIL\VMODE 72M
```

where C:\UTIL is the name for your utilities directory containing VMODE.COM.

3. Shut down and reboot your system.

Win-OS/2 full screen will now be capable of 72 Hz refresh at 640 x 480 and 800 x 600 and 70 Hz for 1024 x 768. Be sure your monitor can handle the higher refresh rates.

Here is a list of VMODE commands and corresponding refresh rates:

Command	Resolution	Refresh rate
VMODE 60Hz	640x480	60Hz
VMODE 72Hz	640x480	72Hz
VMODE 35K	800x600	56Hz
VMODE 38K	800x600	60Hz
VMODE 48K	800x600	72Hz
VMODE 45M	1024x768	87H(i)
VMODE 65M	1024x768	60Hz
VMODE 72M	1024x768	70Hz

(i) = interlaced

AutoCAD, AutoShade, 3DStudio

The Tseng Display list driver for AutoCAD, AutoShade and 3DStudio can optionally be ordered via SPEA's BBS or SPEA's Update Service. See attached Info sheet 'SPEA Expert Line' for more information.

MicroStation

The Tseng driver for MicroStation can optionally be ordered via SPEA's BBS or SPEA's Update Service. See attached Info sheet 'SPEA Expert Line' for more information.

Windows NT

The Tseng driver Windows NT can optionally be ordered via SPEA's BBS or SPEA's Update Service. See attached Info sheet 'SPEA Expert Line' for more information.

Appendix A Utilities

The SPEA Utilities help you to configure or optimize your system environment to get the full use of all the features supported by SPEA. All utilities will be copied into your SPEA directory (C:\SPEA\SHOWTIME) during the basic installation.

STMODE - Setting the Monitor frequency

Use the utility STMODE to change the horizontal frequency of your monitor (e.g. you change the monitor) for DOS applications.

Warning!

You may damage your monitor if you select a frequency that is too high for it! Consult your monitor manual about possible refresh rates.

Start the program from the SPEA directory with the following call:
STMODE /?

You'll see a description of the program and a list of parameters for the different horizontal frequencies you can assign to your monitor.

STTEST - Hardware Test

With STTEST you can check if the hardware components of your SPEA SHOWTIME PLUS are working correctly.

To start the complete hardware test, call the program from the DOS directory without any parameters:

```
STTEST
```

To test only certain parts, call the program with the parameter /?:

```
STTEST /?
```

You'll see a list of parameters to check individual parts of the board.

Note:

STTEST sends an error message if no video signal can be detected at the two video in connectors (Composite and SVHS).

This error message does not mean that the board has a hardware error.

Appendix B Technical Details

Technical Data

Processor: Tseng W32p (PCI or VL)
2 MB DRAM, 135 MHz RAMDAC
HighColor (65536 simultaneous colors) up to 1024 x 768, 75 Hz n.i.
TrueColor (16,7 mill. simultaneous colors) up to 800 x 600, 72 Hz n.i.
Dotclock: depends on the video mode in use (see BIOS.TXT in your SPEA\SHOWTIME directory)

Memory Addresses of the SPEA SHOWTIME PLUS

It is necessary to make sure that all I/O and memory addresses reserved for the graphics board are not used by other hardware devices. The SPEA SHOWTIME PLUS uses the following addresses:

I/O addresses:

Standard VGA I/O	3B0-3DF
Extended Register	217A-217B

Memory addresses:

Video RAM	A000-BFFF
Zoran, Viper chips	BE00-BEFF
Graphics Engine	BFF0-BFFF
Video ROM	C000-C7FF

Video Modes

Tables containing possible video modes (Standard, Extended and Enhanced) can be found in the file BIOS.TXT. This file is installed during the Basic Software Installation into the SPEA directory (C:\SPEA\SHOWTIME).

The Connections of the SPEA SHOWTIME PLUS

The board has 2 outputs and 2 inputs as seen from the side of the board:

Outputs:

1. Audio out (line out). Rating: max. 2.88V on 10 kOhm/100 pF
2. Standard VGA out

Inputs: (PAL, NTSC, SECAM)

1. Composite video in (CVBS/FBAS)
2. S-VHS video in (gives better quality than composite video due to separate signal lines)

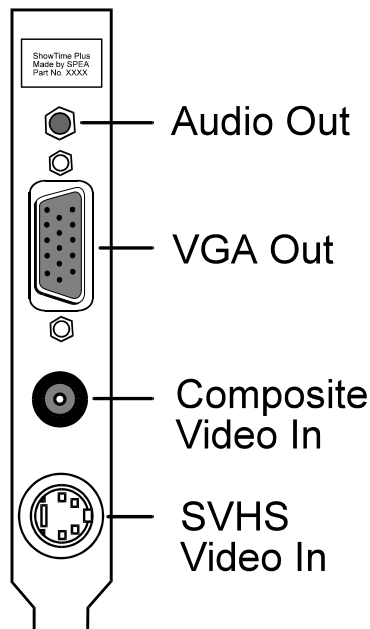

VGA Video Output Connector

The VGA Video Output Connector of the SPEA SHOWTIME PLUS corresponds to the Standard IBM VGA Video output pin-out.

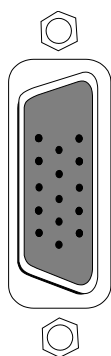

Pin	Function
1	Red
2	Green
3	Blue
4	Not used
5	ground
6	Red Return (ground)
7	Green Return (ground)
8	Blue Return (ground)
9	Key (no pin)
10	Sync Return (ground)
11	not used
12	not used
13	Horizontal Sync (+)
14	Vertical Sync (-)
15	Not used

Pinout of the SPEA Movie Bus

The SPEA SHOWTIME PLUS is equipped with a digital video bus connector. This **is not a Feature Connector**, but the 'SPEA Movie Bus'.

This connector can be used to connect and run a MJPEG board.

The default pinout of this connector is:

Pin	Function	Pin	Function
1	SCL (bi)	2	GND
3	SDA (bi)	4	ODD (bi)
5	FEIN (in)	6	FEOUT
7	HREF (bi)	8	GND
9	HS (bi)	10	VS (bi)
11	LLC2 (bi)	12	GND
13	CREF (bi)	14	GND
15	LLC (bi)	16	GND
17	UV0 (bi)	18	UV1 (bi)
19	GND	20	UV2 (bi)
21	UV3 (bi)	22	GND
23	UV4 (bi)	24	UV5
25	GND	26	UV6 (bi)
27	UV7 (bi)	28	GND
29	Y0 (bi)	30	Y1 (bi)
31	GND	32	Y2 (bi)
33	Y3 (bi)	34	GND
35	Y4 (bi)	36	Y5 (bi)
37	GND	38	Y6 (bi)
39	Y7 (bi)	40	GND

The connector pin numbers are marked on the circuit board itself.

Three operation modes are possible with the SPEA SHOWTIME PLUS:

1. video in (e.g. video cassette recorder, TV Tuner etc.) is active
2. video decoder is active
3. an external board is active

The function of the pinout of the SPEA Movie Bus changes for each mode.

If you need more detailed information about the pinout (and its changes) of the SPEA Movie bus, you can request a technical specification from SPEA Software AG (address to 'Customer Support').

Appendix C Troubleshooting

General Considerations

Make sure the SPEA board is firmly seated in its expansion slot, and that it is not touching other boards in your system.

Be sure your monitor cable is properly connected to the SPEA board and that your monitor power switch is on. You may also need to verify your cable pinout, since some monitors use a non-standard configuration. Make sure other peripherals such as EMS cards, disk controllers or LAN cards are not using the same memory address as the SPEA board. Check with the manufacturer or your user's manual for information about designating exclusions for memory locations when invoking your device driver.

Some other things to think about

Your AUTOEXEC.BAT or CONFIG.SYS file may contain commands that are interfering with the operation of the SPEA board. Try booting your system without these files. If the SPEA board works properly, identify and remove the conflicting command(s).

Systems with motherboard VGA controllers

If your system has a display controller on the motherboard, be sure to disable it before trying to run the SPEA board. Consult your computer's User Manual for the correct switch or jumper settings your motherboard requires.

Hardware settings

When installing the SPEA SHOWTIME PLUS, you should beware of possible hardware conflicts with other adapter cards in the computer. It is possible that two or more cards in the computer are contending for the same resources. These conflicts can involve:

- IRQ line (Interrupt Request)
- DMA channel (Direct Memory Access)
- I/O port address (Input / Output)

Devices to be wary of: When setting up IRQ, DMA and I/O ports, be especially aware of the following hardware: Scanner card, SCSI drive, Tape Streamer, additional sound card, hard/floppy disk drives, modems, serial ports, mice, networks and others.

In a PCI computer, these are set using the system BIOS setup for each expansion slot. Below are details of the various settings:

IRQ settings

The computer is likely to be using various IRQ lines already, through hardware handlers for disk drives, printer ports, keyboard, co-processor, and others. MS-DOS 6 ships with the utility MSD, which you show you what IRQs are/aren't being used. Once you know this information, you can set the IRQs of the SPEA SHOWTIME PLUS correctly. Here is an example to likely IRQ usage:

IRQ 4	active serial port
IRQ 3+4	two active serial ports
IRQ 7	print spooler or SoundBlaster
IRQ 2 or 3	mouse

Q: INSTALL terminates with error 'Wrong IRQ'

A: This is a known problem caused by a BAT file used by the installation. The error message will occur no matter what you do, but you should ignore this error, as it will appear whether there is a problem or not. This fault should be fixed in a forthcoming release of the software.

DMA channels

This is used for board initialisation and digitised sound transfers (recording and playback of WAV files). These are set for each adapter in the computer. You will need to check each card in the computer to establish which DMA channels are in use. This may be set by a jumper on some cards. Be very thorough when allocating DMA channels, and be sure DMA usage is unique to each adapter that uses them.

I/O port address

This is the address at which a particular driver of device can be communicated with.

Configuration Problems with PCI Motherboards

If you have problems with the configuration of your PCI board, there are a number of possible causes.

There are some basic settings you may have to enter manually in your PC's PCI configuration setup menu.

There are many different PCI Setup configuration menus in use on the market, each depending on the mainboard manufacturers choice.

How do you get to the PCI configuration menu?

Via the BIOS Setup of your system (check your PC manufacturer's manual) - e.g. with ESC during the boot procedure.

Warning!

Not all PCI configuration menus offer the same options to the user. In this case the invisible options are set automatically by the system.

Please take note of the following:

- **INT** must be set
- A free IRQ (e.g. 5,9,10,11) must be assigned to each slot and INT A
- The option 'Trigger Method' in the PCI configuration menu must be set to 'Level'. (If in your system 'JPx' is entered at 'Trigger Method', please read in the system manual how to change the entry to 'Level').

Possible problems:

- System does not start properly, but the settings are correct:

Possibly your PCI motherboard has an additional jumper to enable/disable IRQs. In this case, read through the PCI system manual and correct the jumper setting.

- The system is active, but the mouse has disappeared.

It is possible that the PCI slot is not set to INTA, but INTB, C or D. In this case set INTA and assign a free IRQ to the PCI slot.

Frequently Asked Questions

General problems

Q: I have changed my monitor. How do I configure the SPEA SHOWTIME PLUS to use it?

A: If you change the monitor, you should check its specifications against those of the SPEA SHOWTIME PLUS and, if necessary, to change the resolutions and refresh rates using the utility STMODE, in your \SPEA\SHOWTIME directory.

Q: The system does not work properly, some problems occurred while the graphics board has been installed.

The system beeps when booting.

The graphics board cannot be initialized.

Problems with the network occur.

A: Check again, if all connections are correct and if the graphics board is placed secure in the expansion slot. Be sure that you have installed the most up to date software driver. (You can find them in the SPEA mailbox. If you don't have a modem, please contact your local dealer).

Remove all other hardware (e.g. Sound-board, networking card) from your system in order to find out possible hardware conflicts.

The following I/O addresses may not be used from hardware devices as these are the addresses the graphics board uses: 03B0 - 03DF, 217A-217B(hex).

Deactivate all other VGA components in your system (in case a VGA part is built onto your motherboard or several graphics boards are installed in your system). Only one VGA part can be active in a system.

Install the graphics board in another slot or - if possible - in another PC.

BIOS system setup:

Install SHADOW RAM for the Video BIOS.

Minimize the clock rate of your system.

Q: DOS 6.0 (5.0): General Problems with Windows

A: Check the following entries in the CONFIG.SYS file:

HIMEM.SYS, QEMM386.SYS or 386MAX.SYS must stand at the first position.

For memory management no INCLUDE command is allowed. Instead you have to exclude memory areas which are used by other hardware devices (e.g. Scanner, Soundboard a.s.o.) with the EXCLUDE command. For the graphics board this is the area x=A000-C7FF.

Reduce the cache from 2048kB to 1024kB.

Q: The installation program of the SPEA SHOWTIME PLUS does not work correct.

A: Add the following entry to the AUTOEXEC.BAT file and restart your system:
SET COMSPEC=C:\DOS\
COMMAND.COM

Problems with Windows

Q: The Windows startup lasts very long.

A: Create a permanent swap file.

Defragment your hard disk regularly (e.g. with Norton SpeedDisk).

Remove unnecessary entries from your WIN.INI file (e.g. fonts, programs).

Q: Fonts are displayed incorrect.
Icons or Windows are displayed unclear or not complete.
The image scrolls through when clicking on the scroll bar.

Pixels remain on the screen.

The image flickers.

The system crashes.

A: Add the following entry to the SYSTEM.INI file under the section [CAR1K.DRV]:
CHIPSYNC=1

Reduce the refresh rate via the V7SETUP

Reduce the clock rate of the system via the System-BIOS Setup.

Q: Windows or applications under Windows crash.
Mouse functions or icons are not correct.
Wrong colors are displayed.

A: Set - depending on the SETUP of your system - DEQUOPLE REFRESH, REFRESH=HIDDEN, REFRESH=AT-STYLE or REFRESH to 'disabled'.
Use COM port #2 for your mouse.

Q: Working with QEMM 6.x: Windows cannot be started.

A: If you get the message 'no UMBs free' set the following entry into the CONFIG.SYS:
C:\QEMM386.SYS R1:ST:M RAM
X=C000-C7FF

Q: No DOS prompt appears after the termination of Windows.

A: Delete the additional remark 'V7START.DLL' from the entry DRIVERS=MMSYSTEM.DLL in the boot block [boot] of the SYSTEM.INI file.

Problems with MediaStation or Media Player

Q: MPEG files will not play in MediaStation or Media Player

A: Check that you have at least 500 KB free conventional memory on your computer. Do this with the DOS command MEM.

Q: MPEG files don't play properly in Media Player

A:
1. Start Media Player
2. Open a file that you want to play
3. Pick the 'Device' menu
4. If the 'SPEA MPEG + VideoCD ...' option is not listed, the driver has not been found. You should re-install your SPEA SHOWTIME PLUS Software to rectify this.
5. Make sure that 'SPEA MPEG + VideoCD ...' option is selected. It should have a 'correction' mark '✓' to the left of it. If it is not selected, pick it, then select a *.DAT file to load.
6. Pick the 'Configure ...' option. You should see the configuration menu.
7. In the Buffer Transfer section, pick the Reset to defaults button.

Q: When capturing video to an AVI file, I get 'Warning, no frames captured, vertical sync interrupts need to be set'

A: The AVI file created by MediaStation will contain nothing. You should carefully check that each interrupt is assigned to just one device. The best way to view the interrupt assignments is to use MSD (with MS-DOS 6), or NDIAGS (with Norton Utilities v8). If necessary, you should re-install your SPEA SHOWTIME PLUS software.

Q: MediaStation crashes after the program buttons are drawn on the screen (possibly after a re-installation)

A: Delete the file MEDIASTA.MST (which contains the bitmaps drawn).

Q: CD ROM or MPEG file can't be opened

A: You probably don't have enough free system memory to execute the action. Start Windows without network support (WIN /n) or close other applications.

Q: System crashes when opening MPEG files

A: It is possible that the PCI BIOS of your system is causing problems. Try the board in another slot.

Q: Error message when 'capturing':

"Warning: No frames captured. Confirm that vertical sync interrupts are configured and enabled".

A: Call up your PC's BIOS Setup and set a free interrupt for the slot being used (10 or 15 are standard values).

Q: Error message "More global memory needed". MediaStation is terminated.

A: Close other applications and retry.

Q: I get no sound in Media Player, although the pictures are OK

A:

1. Start Media Player
2. Open a file that you want to play
3. Pick the 'Device' menu
4. If the 'SPEA MPEG + VideoCD ...' option is not listed, the driver has not been found. You should re-install your SPEA SHOWTIME PLUS Software to rectify this.
5. Make sure that 'SPEA MPEG + VideoCD ...' option is selected. It should have a 'correction' mark '✓' to the left of it. If it

is not selected, pick it, then select a *.DAT file to load.

6. Pick the 'Configure ...' option. You should see the configuration menu.

7. In the Audio section, ensure that the L and R volume sliders are at the top of scale, then pick the Close button.

Q: MPEG files are played back without sound in MediaStation.

A: Check that **active loudspeakers** or a sound board are/is connected to the audio output of the board. Call the Windows MediaPlayer (MPLAYER.EXE), open a file and open the Options menu, click on Configure and set the volume to maximum. Check that the volume level in MediaStation is turned up and that the volume is not muted.

If you are using a sound card with an additional volume control, make sure that it is not muted or at a low level.

Note that it is possible that the MPEG file doesn't have an integrated audio track (a separate WAV file can't be simultaneously played back).

Q: AVI files are played back without sound.

A: This feature is currently under preparation. Please check the README file supplied.

Q: VPG files are played back without sound.

A: This type of file doesn't contain a sound track.

Q: Video In images aren't shown.

A: Check that the correct TV format and input are selected in the Video In advanced settings dialogue box.

Change the video input used (e.g. from Composite Video to S-VHS, which gives better quality anyway).

Q: MPEG file can't be rescaled to fullscreen.

A: The MPEG picture size is too small. The limit is twice the original size.

Problems with VideoCDs

As Video CD is a very new technology, it is likely that many of you are using the format for the first time. In the same way that you encounter picture problems with VHS tape recordings, you can encounter comparable problems in the VideoCD format. This section describes various symptoms and their causes.

Picture display problems can be internal to the quality of the pictures on the VideoCD. Not all VideoCDs have the same picture quality, and thus the resulting picture quality at playback may not be constant for all VideoCDs.

Macro-blocking: Also known simply as 'blocking' or 'jagging', is caused by a lack of bits (binary digits) to store all the information, and happens when the VideoCD movie is created. The area of the picture for which there is insufficient information (bits) will be displayed as simple 8x8 or 16x16 blocks.

Unreal stillness: This is when an object (such as a tree in the background) appears to be absolutely motionless. This can happen during VideoCF creation, where the object is moving so slightly as for the motion to be ignored by the movie conversion process.

Digital rain: This term describes a number of undesirable picture effects. One example of this is a small stationary object that appears in one frame, then disappears for a few frames, then reappears. This and other effects tend to be more apparent in earlier VideoCDs than ones more recently created.

Mosquitoes: This effect can occur especially at the edges of moving objects, due to the number of bits of data concentrated about the point of movement. It can give the impression of a heat-haze or fuzziness in the picture.

The picture quality of VideoCDs made in America can vary from those made in Europe. American manufacturers favour sharper images, which can be clearer but are more prone to the above problems. European manufacturers favour a softer image, which can look more pleasing, and are less prone to the above problems.

Note:

A VideoCD cover that is not marked 'VideoCD' is not suitable for use with the Whitebook CD-ROM standard, and will therefore not be compatible with your system. Unfortunately, VideoCD labelling is not as consistent as it might be, so check with the sales staff before making your purchase.

Problems with CD ROM Drives

If you have problems with your CD-ROM drive consider the following general notes:

There are three types of CD-ROM available, that conform to different standards, and are not therefore compatible with each other. They are as follows:

Yellowbook: Conventional CD-ROM

Greenbook: Used for linear video, typically used in Philips CD-I players (384 lines)

Whitebook: Used for digital video VideoCD (352 lines).

Warning!

To play VideoCDs with the SPEA SHOWTIME PLUS you must have a Whitebook type CD-ROM drive. As the VideoCD format of data is very new, older type CD-ROM drives may not be able to read the data. If you do have problems reading data from a VideoCD, you may find that a software update for your CD-ROM drive will help.

- Only use CDs explicitly labelled 'VideoCD'.
- Check that SMARTDRV.EXE is being loaded *before* MSCDEX.EXE (CONFIG.SYS)
- Use the latest driver version for your CD-ROM drive; it is possible that older driver versions are not able to read the VideoCD format.
- To read CDs you need about 500 KB conventional memory. You may see an error message that the CD cannot be read or messages that the SPEA MCI driver does not work correctly. In this case, delete or REM out all drivers you don't need urgently from your CONFIG.SYS and AUTOEXEC.BAT file and restart your system.
- Only use CD-ROM drives that support the default reading access and fulfill the ISO 9000 rules. A list of CD-ROM drives tested by SPEA can be found in the README file in the SPEA directory.

Appendix D

Glossary

Analog Display

A monitor that uses variable color control voltages to display a very large number of colors but requires very few inputs.

ANSI

American National Standards Institute.

ASCII

American Standards Committee on Information Interchange. A standard used by IBM and compatible computers to represent numbers and characters in binary form.

Authoring Systems

Authoring systems are used to create multimedia applications. They combine existing presentation information (texts, images and sound) and control the flow of these during the multimedia show. The dialogue with the user is controlled with this software. The individual information must have already been created and saved with special programs.

AUTOEXEC.BAT

A batch file that directs the activities performed by the computer during system startup.

AVI

Audio Video Interleaved. AVI files are the standard format for digital video films on PCs.

Bandwidth

The required capacity for the data volume and transmission rate.

BIOS

Stands for Basic Input-Output System. Code in your computer's ROM (Read Only Memory) that provides the power-on self test and other operating functions.

BitBit

Bit Block Transfer refers to the ability of a system to move pixel blocks (in a rectangular area, e.g. in a window) very quickly. The contents of the rectangular area are rapidly refilled with the original contents.

BMP (Windows Bitmap)

This format enables Microsoft Windows to display images on devices with similar capabilities in a consistent way. Save pictures in this format if you wish to continue to process them later under Windows.

Booting/Booting Up

Starting the computer. There are two types. Warm Booting is accomplished by simultaneously pressing the CTRL/ALT/DEL keys and can occur only when the computer is running. A cold boot requires activation of the ON/OFF switch.

Brightness

The brightness of an image is determined by the amount of light emitted by it. No light (black) therefore means 'no brightness', whereas pure white light means 'maximum brightness'.

CD-I

Compact Disc Interactive. A technique developed by Philips in order to playback games, films and music videos on a CDI player.

CD-ROM

High-density medium to store digital data. CD-ROMs have read-only status. There are different CD-ROM formats:
YellowBook: conventional CD-ROM format
GreenBook: used for linear video, this is typical for CD-I's (see below)
WhiteBook: used for Digital Video VideoCDs.

CGA

The IBM Color Graphics Adapter.

Channel Number

A MIDI device can have three connections - MIDI-In, MIDI-Out and MIDI-Through. The last is used to pass on data group information without changing it. This enables the user to cascade several devices. To select a particular device, the MIDI information is passed on to an identifying channel number from 1 to 16.

Cinepak

Software-Codec. Makes fast decoding possible. Good image quality possible as long as the image dimensions are not increased. The video encoding process is time-consuming.

CODEC

Compressor / Decompressor, responsible for the compression and decompression of image data.

Color Display

A type of monitor capable of displaying information in color. It is often called an RGB (red, green, blue) monitor, referring to the signals needed to drive it.

Color Palette Conversion

Conversion of video data from the YUV color model into the RGB color model, or v.v.

CONFIG.SYS

An ASCII file that is created to provide the computer with special information about applications and hardware.

Contrast

The contrast of an image is the difference between light and dark. A contrast-intensive image is one in which contains strong transitions from light to dark. A contrast-weak image contains transitions that are hardly noticeable.

Data Transfer Rate

The data transfer rate describes the amount of data transferred to or from the storage medium (e.g. hard disk) per second. Each data storage medium has a specific data transfer rate which it can handle. Typical values are:

- old hard disks 300 KB/s
- new hard disks 600 KB/s
- standard CD-ROM drives 150 KB/s
- DoubleSpeed CD-ROM drives 300 KB/s

DCI

Display Control Interface. An interface defined by the Intel and Microsoft corporations, which enables enhanced graphics performance due to direct access to the video memory.

Default Mode

The capabilities, resolutions and display mode the system operates with when you start your computer.

Digital Display

Also called TTL. A type of monitor that switches signals ON or OFF to determine display color. Types of digital displays include the IBM Enhanced Color Display or Monochrome Display.

Digital Video

Digital videos contain optical information bitwise in a file.

DIP Switch

Dual Inline Package switch; a series of tiny, two position switches which allow users to select and change options on computer boards, printers, and other peripherals.

Driver

Part of a software program that interacts with a particular piece of equipment in your computer system (i.e. video boards, printers, and keyboards). Drivers are often loaded by your config.sys at system boot.

Dropped Frames

The images of a video which are not displayed or recorded when replaying (resp. recording).

EEPROM

Electrically erasable programmable read only memory; used to replace DIP switches and jumpers on new graphics boards like yours.

EGA

The IBM Enhanced Graphics Adapter.

EMS

Enhanced Memory Specification. Originally developed to break the DOS 640K limit, it is now used as a general term for types of add-in memory.

Enhanced Color Display (ECD)

The IBM Enhanced Color Display capable of 640 x 350 resolution.

EPS (Encapsulated PostScript)

EPS is a device-independent file format, which contains all the information required to reproduce an image directly on a PostScript printer or to use it in suitable applications. A small header section contains the data of the image as a TIFF-format file so that applications that can not display PostScript data directly can still obtain an impression of the file contents.

Expansion Board

A device used to expand a computer's capability.

Expansion Slot

An electrical connection within the computer used for the addition of Expansion Boards.

Fill-in Images

When video data is being saved onto a CD-ROM (during manufacturing) the images are normally 'polstered' with fill-in images so that each video file completely uses the assigned 2KB area. This ensures a constant data rate and a smoother playback appearance. The file size is not changed by doing this.

Fixed Frequency Monitor

An analog monitor which can only sync to a very narrow range of scan frequencies.

fps

frames per second. Measurement unit for the frame rate.

Frame

Single video image.

Frame Rate

Number of images shown per time unit. Software videos have a fixed frame rate. When playing back the actual frame rate achieved can differ to the rate defined in the video considerably.

Framegrabber

If an overlay board (see below) also contains a realtime video digitizer (= frame grabber), then the user can capture a random frame from the video sequence being replayed and can save this onto his hard disk.

General MIDI

The MIDI Association's MIDI Song File standard has established itself as the General MIDI standard for the exchange of MIDI music data between different PC systems.

GIF (Graphics Interchange Format)

A graphics file format developed by CompuServe to enable the device-independent exchange of images between systems. GIF-format files can be up to 64MB in size with color information up to 256 colors (8 bits). GIF files do not contain information about the image resolution.

Greyscales

A greyscale image consists of different shades of grey (like a black-and-white photograph). This normally means that 254 different greyscales plus black and white (= 256) are used.

Hardware Cursor

The cursor's movements and display are controlled by the accelerator chip. This means that the CPU only has to pass the mouse coordinates to the graphics board, reducing the CPU's workload.

Hercules Graphics Card (HGC)

A video adapter that provides bit mapped single color graphics.

Hexadecimal Notation

A base-16 numbering system that uses numbers and letters. The hexadecimal sequence begins: 1 2 3 4 5 6 7 8 9 A B C D E F, then 10, 11 etc.

Horizontal Frequency

The rate at which a monitor displays each scan line. Usually measured in kilohertz (kHz).

I/O Port

Input/Output port. An address used to access a hardware device.

Image Compression

Technique used to reduce the volume of data in digital image and video files.

INDEO

Intel Video. Compression technique developed by Intel. Gives good quality but requires a high level of processing work to decompress.

Indexed 16 and 256 Color Images

Indexed color images contain a color table in the file. This table lists all the colors that could be used in the file. An indexed 16-colour image contains a table with 16 colour entries (4 bits) whereas an indexed 256 colour image 256 colours are listed (8 bits).

Other colors can be simulated in a way similar to using greyscales in a black-and-white image, by simply positioning the pixels in varying densities. The eye then sees color mixtures that are not actually in the color table. You can transform images into indexed color images in order to load them into programs such as Windows Paintbrush, or just to see them on monitors that can only display 256 or 16 colors.

Interlaced Display

A monitor that refreshes every other scan line every other pass of the screen. A non-interlaced monitor refreshes the entire screen (every scan line) every pass of the screen.

Interleave

A technique used to organize audio and video data so that every audio data segment is followed by video data, e.g. AVAVAV.....

Interrupt Request (IRQ)

Signal used by a device, such as a mouse, to inform the CPU that it is present and functioning.

JPEG

A new compressed file format industry standard developed by the Joint Photographic Experts Group. It enables compression ratios up to 100:1 (original file size to compressed file size). A new feature of this standard is that it is device-independent. These files can be replayed using any application that supports this format. JPEG differs from the LZW compression method in that it works without quality loss. This means that some of the original data is lost during the compression phase. In order to surpass this visual effect JPEG compression attempts to 'lose' information which is less important to the human eye. Use this format if you don't have much memory space available or if you are processing very large image files.

Jumper

A small plastic plug that fits over a pair of pins. When the plug straddles two pins it makes an electrical connection. The computer makes decisions based on whether the connection is made or not. A group of jumper pins is called a jumper block.

Keyframe

Technique used to compress video data whereby certain frames are defined as 'keyframes' and are fully saved during compression. The video data of the frames between two keyframes are only partially stored. During decompression the 'partial frames' use the information stored in the keyframes.

Line Drawing

This is a hardware function of the graphics processor chip. Only the starting and ending co-ordinates of a line are supplied by the CPU. The rest of the work drawing the line is then done by the graphics processor.

M-JPEG

Motion JPEG. A codec (see above), which is especially suited to video processing. Hardware decompression is strongly recommendable for this.

MDA

The IBM Monochrome Display Adapter.

MIDI

Musical Instrument Digital Interface. A serial interface used to link computers, synthesizers and other electronic sound generating devices.

Monochrome Display

Monitor that displays information in one color only; sometimes called a black & white display.

MPC

Multimedia PC. This trademark is intended to help consumers when purchasing hardware and software (similar to the VHS symbol used in the video product market).

MPEG

Motion Picture Expert Group. The compression method known as MPEG 1 is suited to digital video playback. A hardware decompressor is necessary.

MPEG

MPEG stands for Motion Pictures Experts Group, a group of the ISO committee for standards. With the MPEG format an international standard for the display of 25 images per second and a transmission rate of between 150 and 300 KByte per second is defined. Through a highly sophisticated compression method MPEG is a way to display full screen and full motion video with CD sound quality using little memory. This way, MPEG files can be played back as well as Video CDs, interactive programs and presentations.

MT-32

The MIDI module MT-32 created by Roland.

Multi-frequency Monitor

A type of monitor that supports a wide range of horizontal scanning frequencies and vertical refresh frequencies. This type of monitor accepts inputs from many different video display adapters.

NTSC

National Television Standards Committee. The committee responsible for the definition of the north american television standard (with the same name). NTSC creates 30 images per second.

Overlay Boards

Overlay boards are able to digitize video images being input in realtime, to synchronize the data with the random segment of the screen and to show both images (incoming video signal and background screen image) simultaneously on the PC's monitor. The result is a window showing a video film which is placed over a background (e.g. a Windows application).

PAL

Phase Alternation Line. PAL is the television standard used in Germany and Great Britain. The video signals are transformed into 25 images per second.

Palette

A selection of colors from which to choose. Your board provides as many as 16.7 million simultaneous colors from a palette of 16.7 million. This capability is sometimes referred to as TrueColor. It is believed that the human eye can discern no more than 16.7 million colors.

PCX (PC Paintbrush)

This file format was developed by Zsoft Corporation for PC Paintbrush, one of the first computer drawing programs. It is the standard format for many scanners and drawing programs. Some versions of the PCX format don't contain any information about the resolution of the image.

Peripheral Equipment

Auxiliary equipment connected to a computer (e.g. monitor, printer, keyboard, etc.).

Pixel

Short for picture element; the smallest field displayed on the monitor; could be compared to the dots which form images in photos printed in newspapers. Also called pel.

Poligon Fill

A special hardware (chip) routine used to fill polygons with pixel information.

Primary Display

The monitor that is active when you power on your system.

PS/2 Display Adapter

The IBM VGA board for Industry Standard Architecture (AT bus) computers.

RAM

Random Access Memory; memory that can be read from and written to.

Resolution

The number of pixels (from picture cells) in both horizontal and vertical directions.

Resolution

Number of pixels displayed on the monitor. The higher the resolution, the crisper and sharper the images appear.

RGB 8Color

RGB8 color file types are 3 bit types in which each pixel can have one of 8 colors. The RGB8 color images are automatically transformed into indexed 16 color images whereby the 8 colors are retained but space for further 8 colors is created. It is not possible

to transform an existing file into an RGB8 color file type.

RGB Color Model

Monitors use additive mixing of the three basic colors red, green and blue to create images on the screen with an infinite number of colors. Image data is therefore processed via data for RGB color combinations. The combinations of the three basic colors create a color model whose origin is the colour black and the opposite value is the color white.

RGB True Color

RGB stands for red - green - blue. All the colors that are used in this file are created additively mixing parts of the three basic colors. The parts of the three basic colors can be varied in 256 steps. If you mix all these colors together a total of 16.7 million possible color combinations is attainable ($3 \times 8 \text{ bits} = 24 \text{ bits}$, 2 to the power of 24 = 16.7 million). As the human eye can not tell the differences between color hues from about this level, such an image is termed 'True Color', i.e. 'as in real life'.

ROM

Read Only Memory; memory space in your computer for storing permanent operating instructions.

Sample Frequency

If the data bandwidth is fixed then the incoming signal to a processing unit can be assigned to a whole number (value). The quantity of such values (samples) that can be taken per second is referred to as the sample rate or frequency.

Sampling Depth

Describes the number of bits used for each sampled value of the sound input. 8 bits are suitable for microphone recordings, 16 bits give higher quality but require twice the memory storage space.

Sampling Rate

Analogue accoustic signals are digitized by the analogue/digital converter (ADC) on your sound or video board. The ADC component samples the audio signal in extremely short time intervals and stores the measured values. The number of sampled values per second is the 'sampling rate'. The usual rate for a low-quality recording of speech is 11.025 kHz. Better quality speech recordings or low-quality music recordings are sampled at 22.05 kHz. CD quality is attained at 44.1 kHz.

Saturation

The saturation refers to the purity of a color. A

color with a high saturation value is optically very intensive. A color with a low saturation value appears weak (i.e. with less color content).

Scaling

Transformation of image data to different sizes.

Secondary Display

The monitor connected to the graphics card that is co-resident with another card/monitor in your computer system. Is not active upon booting your system.

Sound Files

The most common file type for sound files under Windows are WAV files.

Sync

The stable condition that exists when two repetitive events maintain a constant time relationship; your monitor is in sync with the signals from your board when the display is correct and stable.

Terminate and Stay Resident (TSR)

Programs that are run once then remain in memory in order to be activated by a sequence of key strokes or a 'hotkey.' It is possible that a TSR may take up too much memory and cause conflicts with other programs.

TGA (Targa)

Developed by the company True Vision especially for its true color video boards (especially the Targa board), this is a format preferred by many specialists.

TIFF (Tagged Image File Format)

This format was developed by Aldus and Microsoft in order to promote the use of desktop scanners and DTP systems. Uncompressed TIFF files are hardware and software-dependant, however there are different incompatible compression methods. Select this format for the maximum compatibility with other applications and to improve the compression level.

TrueColor

The ability to display 16.7 million simultaneous colors. It is believed that the human eye can discern no more than 16.7 million colors. See 'palette'.

Variable Frequency Display (VFD)

A monitor that is capable of displaying a wide range of resolutions through its ability to sync to a wide range of horizontal and vertical scan frequencies.

Vertical Frequency

The rate at which the monitor screen is refreshed. Usually measured in hertz (Hz).

VGA

The IBM Video Graphics Adapter.

Video CD

The VideoCD specification was published in 1993 by JVC, Matsushita, Sony and Philips as the so-called 'Whitebook' standard. Using this up to 74 minutes of digital video compressed with the MPEG 1 technique can be stored on a CD. The image resolution is 352 x 240 pixels and 30 frames per second for the NTSC standard and 532 x 288 pixels at 25 fps for PAL.

Video Connector

The standard 15-pin monitor output connector located on the board.

Video Electronics Standards Association (VESA)

industry-wide consortium organized to standardize graphic modes. Your board supports the VESA standards.

Video Keying

This term refers to the process of mixing two video and computer graphics signals.

YUV Color Palette

The image information of individual frames is comprised of a brightness part and 2 color parts. The color part is calculated by evaluating the difference to the brightness value. This method was first utilized in television technology.

YUV Signal

A video signal that is comprised of a brightness part (luminescence Y) and two color parts (chrominance U and V). Due to the characteristics of the human eye, it is enough to transfer the color parts with a lower resolution. This mixture is technically achieved by only evaluating 2 chrominance signals U and V compared with the 4 values calculated for the luminescence. This results in statements in the format 4:2:2. Other constellations are possible.

Zooming

Increased display of an image section.

Index

3		Outputs	24
3DStudio.....	22	P	
A		PCI cards	10
Address.....	7	PCI Motherboards.....	27
Audio Out.....	12	Playback.....	20
AutoCAD.....	22	Q	
AutoShade.....	22	QEMM386.....	28
C		R	
CD ROM.....	30	README.....	7
Composite Video In.....	12	S	
Connections.....	24	Single Frame Capture.....	21
D		Software.....	8
DPMS.....	18	Software Delivery Scope.....	8
E		Sound board	12
External Equipment.....	12	SPEA Movie Bus.....	12; 25
G		SPEA WinTools.....	18
Glossary.....	31	SPEAenergy (DPMS).....	18
H		STMODE.....	23
Hardware Compatibility	15	STMODE.EXE.....	15
Hi-Fi system	12	STTEST.....	23
I		Support.....	7
Inputs	24	SVHS Video In.....	12
Installation with a sound card.....	13	System Configuration.....	9
Installation without a sound card.....	14	T	
L		Technical Data.....	24
Loudspeakers	12	Troubleshooting.....	26
M		V	
Media Player.....	19	V7SETUP.....	18
MediaStation.....	19	VGA Video Output Connector.....	25
Memory Addresses.....	24	Video In Capture.....	20
MicroStation.....	22	Video Modes.....	24
MJPEG.....	12	VL cards	10
Monitor Compatibility.....	9	W	
O		Warranty.....	7
OS/2.....	21	Windows 3.1x.....	17
		Windows NT.....	22
		WIN-OS/2.....	22